

Mental Math Games

Path to Glory Game

This is a game for two players. The object is to be the first player to reach 100 exactly.

Directions

Start at 0. Take turns adding one of the following numbers: 1, 2, 8, 9, 15, 16, 24, 25, or 26. Write the number you add in a circle. Write the sums in the squares as you go.

Example: $\boxed{0} \rightarrow (+16) \rightarrow \boxed{16} \rightarrow (+2) \rightarrow \boxed{18} \rightarrow (+9) \rightarrow \boxed{27} \rightarrow (+25) \rightarrow \boxed{52}$

0 → + → □ → + → □ → + → □

↓

+ → □ → + → □ → + → □ → +

↓

□ → + → □ → + → □ → + → □

↓

+ → □ → + → □ → + → □ → +

↓

□ → + → □ → + → □ → + → □

0 → + → □ → + → □ → + → □

↓

+ → □ → + → □ → + → □ → +

↓

□ → + → □ → + → □ → + → □

↓

+ → □ → + → □ → + → □ → +

↓

□ → + → □ → + → □ → + → □

Copyright © Kendall Hunt Publishing Company

Path to Glory: Challenge

This is a cooperative activity for two players. The object is to reach 100 in exactly 11 steps.

Directions

Work with a partner. Start at 0. Take turns adding 1, 2, 3, 10, 20, or 30. Write each number you add in a circle. Write the sums in the squares as you go. Can you reach 100 in exactly 11 steps?

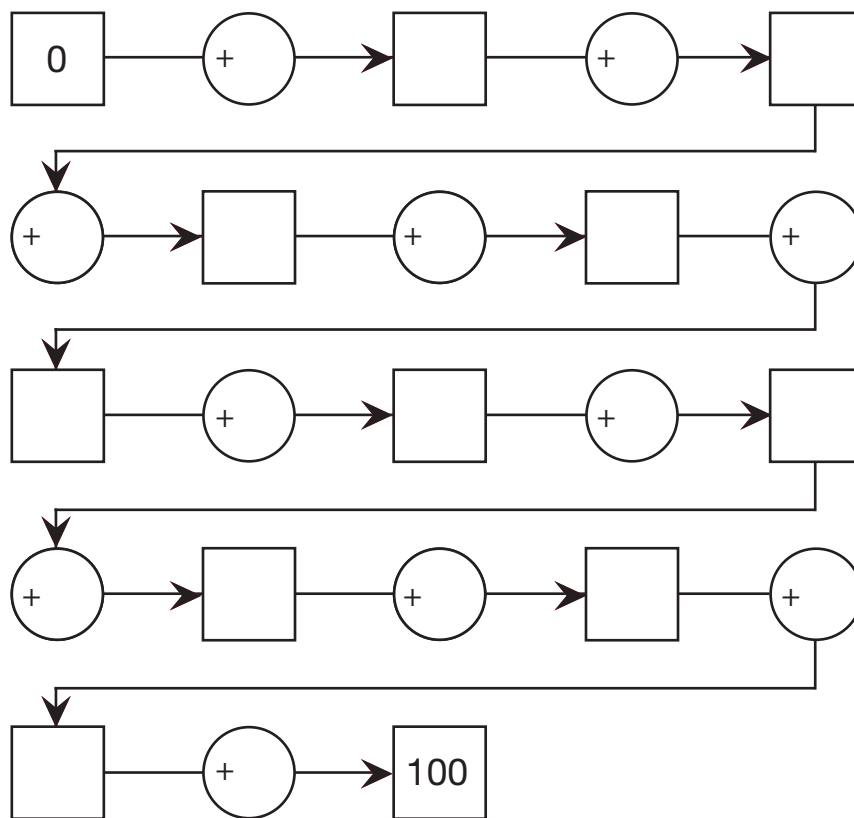

Is there another way to reach 100 in exactly 11 steps? Write about what happened.

