

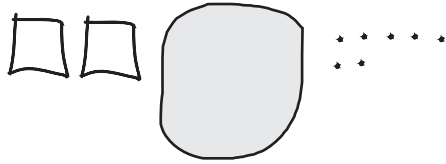

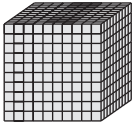

**C.** Here is a third way to show 267.



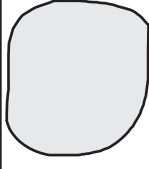

**Base-Ten Recording Sheet**

 1000s	 100s	 10s	 1s
	2		7

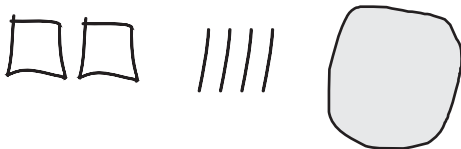
**D.** Here is yet another way to show 267.



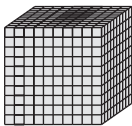
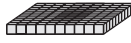

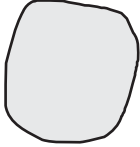
**Base-Ten Recording Sheet**

 1000s	 100s	 10s	 1s
	2	4	

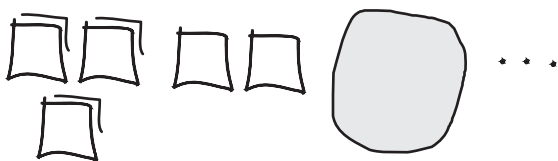
**E.** Here is a way to show 3303.

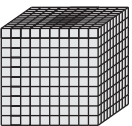
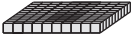

**Base-Ten Recording Sheet**

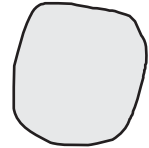
 1000s	 100s	 10s	 1s
3	2		3