

Student Guide

Measuring and Estimating Angles

Questions 1–20 (SG pp. 384–393)

1. Yes; $\angle X$ is a little larger than 90° , and 100° is the only choice that is above 90° .
2. Kenya's estimate is better; $\angle Y$ is only a little smaller than 90° , so 85° is a better estimate than 60° .
3. $\angle YXW$ is a little under 90° , so it is around 85° .
 $\angle S$ is a little over 90° , so it is around 95° .
 $\angle Z$ is a little under 180° , so it is around 170° .
 The inside of $\angle R$ is 90° , so it is $360^\circ - 90^\circ = 270^\circ$.
 $\angle TUV$ is about halfway between 90° and 180° , so it is around 135° .
4. Ana is right that $\angle R$ is more than 90° , but it is actually quite a bit more, not a little as she says. The opposite side of the angle is 90° , so $\angle R$ is $360^\circ - 90^\circ = 270^\circ$.
5. Less than 90°
6. $\angle ABC$ is about halfway between 45° and 90° .
7. 70°

Measuring and Estimating Angles

Estimating Angles

Mrs. Dewey drew two angles and wrote five angle measures on the board. She asked the class to choose the best estimates for the size of $\angle X$ and $\angle Y$.

1. Linda decided the best estimate for $\angle X$ is 100° .

Do you agree with Linda? Why or why not?
2. John and Kenya had different estimates for $\angle Y$. John estimated 60° and Kenya estimated 85° . Which do you think is a better estimate? Explain your choice.

384 SG • Grade 4 • Unit 9 • Lesson 4 Measuring and Estimating Angles

Student Guide - Page 384

3. Describe the estimated size of the following angles. Use a square corner or other right angle as a guide.
4. Ana wrote about $\angle R$ in Question 3.
 $\angle R$ is a little more than 90° .
 Do you agree with Ana? Why or why not?

Using a Protractor

5. Is $\angle ABC$ less than or greater than 90° ?
6. Describe the size of $\angle ABC$.
7. Choose your best estimate for $\angle ABC$.
 30° 120° 70° 90° 89°

Measuring and Estimating Angles SG • Grade 4 • Unit 9 • Lesson 4 385

Student Guide - Page 385

Answer Key • Lesson 4: Measuring and Estimating Angles

Luis used a **protractor** and the following steps to find the degree measure of $\angle ABC$.

Copyright © Kendall Hunt Publishing Company

- He placed the center of the protractor over the vertex of the angle.
- \overline{BC} lined up with the 0° mark on the right side of the protractor. He began at 0° and read the degree marks until he reached \overline{AB} .
- Since the angle was less than 90° , Luis decided that $\angle ABC$ measured 70° .

- Look back at your estimate of $\angle ABC$ in Question 7. Did you make a reasonable estimate?
- Look at $\angle TUV$. Is $\angle TUV$ less than or greater than 90° ?
- Describe the size of $\angle TUV$.

- Choose your best estimate for $\angle TUV$.
 75° 45° 90° 120° 20°

386 SG • Grade 4 • Unit 9 • Lesson 4 Measuring and Estimating Angles

- Answers will vary.
- Less than 90°
- $\angle TUV$ is about halfway between 0° and 90° .
- 45°
- $\angle TUV$ is under 90° , so it is between 40° and 50° .
 - 45°
 - Answers will vary.
- Greater than 90°
 - It is clearly greater than 90° , but closer to 90° than 180° .
 - 120°
- $\angle DEF$ is greater than 90° , so it is between 120° and 130° .
 - 123°
 - The estimate of 120° is very close.
- It is about halfway between 270° and 360° .
 - 330°

Student Guide - Page 386

- Look where ray \overline{UT} is pointing. The angle's measurement is either between 40° and 50° or 130° and 140° . Which is it?
 - Read the numbers starting with the 0° mark. If each mark is 1° , what is the angle measure for $\angle TUV$?
 - Look back at your estimate in Question 11. Did you make a reasonable estimate?
- Look at $\angle DEF$.
 - Is $\angle DEF$ less than or greater than 90° ?
 - Describe the size of $\angle DEF$.
 - Choose your best estimate.
 65° 95° 120° 160° 30°

Copyright © Kendall Hunt Publishing Company

Measuring and Estimating Angles SG • Grade 4 • Unit 9 • Lesson 4 387

Student Guide - Page 387

- Look where ray \overline{ED} is pointing. The angle's measurement is either between 50° and 60° or 120° and 130° . Which is it?
 - Read the numbers starting with the 0° mark. If each mark is 1° , what is the angle measure for $\angle DEF$?
 - Compare your measurement to your estimate.
- Look at $\angle Z$.
 - Describe the size of $\angle Z$.
 - Choose your best estimate.
 30° 60° 350° 270° 330°

Copyright © Kendall Hunt Publishing Company

388 SG • Grade 4 • Unit 9 • Lesson 4 Measuring and Estimating Angles

Student Guide - Page 388

Copyright © Kendall Hunt Publishing Company

16. **A.** Jerome's measurement is wrong. He is measuring the inside of the angle, instead of the outside.
B. $360^\circ - 30^\circ = 330^\circ$
- 17.* See the lesson. Jackie read the wrong set of numbers.
18. Drawings will vary. Students should correctly identify each type of angle, name each ray, and indicate the measurement of each using the degree label appropriately. One of the three angles should have the vertex on the right side and one on the left.
19. Drawings and number sentences will vary. Using Maya's strategy, a possible number sentence for a reflex angle measuring 270° is $360^\circ - 90^\circ = 270^\circ$.

16. Jerome used a protractor to find the degree measure of $\angle Z$.

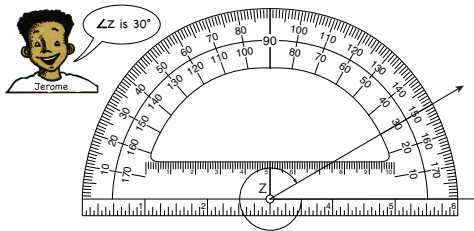

A. Compare Jerome's measurement to your estimate. Is his measurement reasonable? Why or why not?
B. Look at Maya's thoughts and strategy.

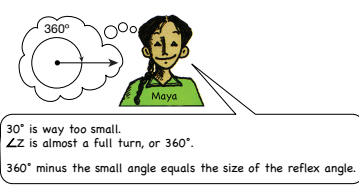

Finish Maya's strategy to find the measurement of $\angle Z$.

Use the *Measuring Angles* pages in the *Student Activity Book* to practice measuring with a protractor.

Copyright © Kendall Hunt Publishing Company

Measuring and Estimating Angles SG • Grade 4 • Unit 9 • Lesson 4 389

Student Guide - Page 389

Using his ruler, Frank then connected the vertex with the dot he drew. His angle looked like this:

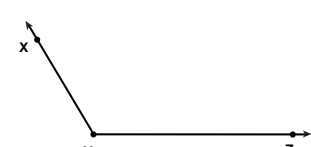

17. Jackie tried drawing a 105° angle. This is her drawing. Explain her mistake.

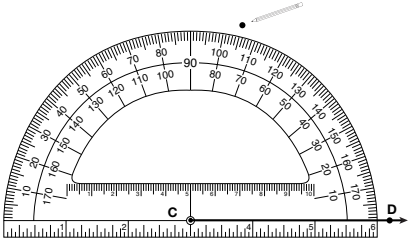

18. Use Frank's method to draw angles on a separate piece of paper. Use the following guidelines to complete your drawings.

- Draw and identify each of these three types of angles: acute, right, obtuse.
- Name each angle and give its measurement.
- Make at least one angle with a vertex on the right side and one on the left side.

19. Draw a reflex angle. Name your angle and give its measurement. Write a number sentence to show how to calculate the measurement.

Copyright © Kendall Hunt Publishing Company

392 SG • Grade 4 • Unit 9 • Lesson 4 Measuring and Estimating Angles

Student Guide - Page 392

*Answers and/or discussion are included in the lesson.

20. Grace drew this:

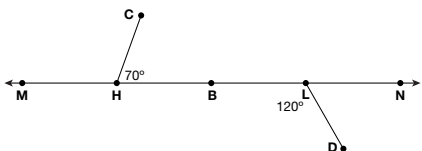

She made $\angle CHB$ 70° . Look at Grace's thinking to determine the measurement of $\angle CHM$.



$\angle CHM + \angle CHB = 180^\circ$
 $\angle CHM + 70^\circ = 180^\circ$
 $\angle CHM = 110^\circ$

- Do you agree with Grace? Measure to check her calculations.
- Write a different number sentence to determine the measurement of $\angle CHM$.
- What is the measure of $\angle DLN$?
- Write a number sentence to calculate the measurement of $\angle DLN$.

Copyright © Kendall Hunt Publishing Company

Use the *Draw and Solve Problems with Angles* pages in your *Student Activity Book* to practice drawing angles and using number sentences to determine the measurement of angles.

20.

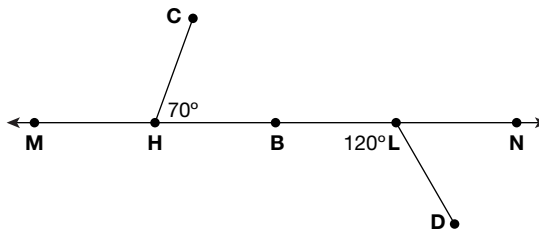

- Students should agree with Grace's thinking, recognizing that MB is 180° , thus calculations can be made following Grace's strategy to determine the measurement of $\angle CHM$.
- $180^\circ - 70^\circ = 110^\circ$
- 60°
- Possible response: $180^\circ - 120^\circ = 60^\circ$

Student Guide

Homework

Questions 1–6 (SG pp. 394–395)

1. Michael's estimate is correct for the angle $\angle DEF$ as it is shown, Irma's estimate is correct for the reflex of $\angle DEF$.
2. 260°
3. true; false; false; true; true
4. true; true; true; false
5. false; true; true; true
6. true; false; false; true



Michael and Irma described the size of $\angle DEF$.

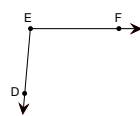

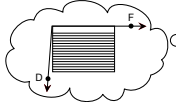

Michael

$\angle DEF$ is a little larger than 90° . I used my cardboard right corner.

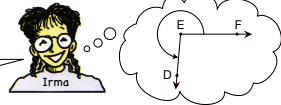

Irma

$\angle DEF$ is a reflex angle that is larger than a half turn and close to a $\frac{3}{4}$ turn, or 270° .

1. Whose estimate do you agree with, Michael's or Irma's? Explain your reasoning.
2. Choose the best estimate for reflex $\angle DEF$.
 280° 260° 80° 100° 330°

Copyright © Kendall Hunt Publishing Company

394 SG • Grade 4 • Unit 9 • Lesson 4
Measuring and Estimating Angles

Student Guide - Page 394

Write true or false for each statement.
Use a corner of a piece of paper to help you.

3. $\angle M$ is smaller than a right angle.
 $\angle M$ is larger than a right angle.
 $\angle M$ is an obtuse angle.
 $\angle M$ is an acute angle.
 $\angle M$ is closer to 0° than 90° .
4. $\angle N$ is larger than an acute angle.
 $\angle N$ is smaller than a reflex angle.
 $\angle N$ is between 90° and 180° .
 $\angle N$ is between 270° and 360° .
5. $\angle OPQ$ is an obtuse angle.
 $\angle OPQ$ is a reflex angle.
 $\angle OPQ$ is larger than 180° .
 $\angle OPQ$ is closer to 360° than 180° .
6. $\angle R$ is an obtuse angle.
 $\angle R$ is close to 180° .
 $\angle R$ is a little smaller than 90° .
 $\angle R$ is a little larger than 90° .

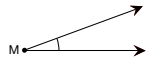
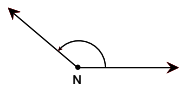
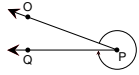
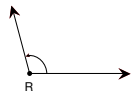
Measuring and Estimating Angles SG • Grade 4 • Unit 9 • Lesson 4 395

Student Guide - Page 395

Student Activity Book

Measuring Angles

Questions 1–2 (SAB pp. 323–324)

1. **A.** Responses will vary.
B. 60°
C. Responses will vary.
2. **A–C.** Responses will vary.

Name _____ Date _____

Measuring Angles

1. Maya measured $\angle F$ from the Angle Sort Cards. She taped the card in the center of the paper and extended the rays of the angle.

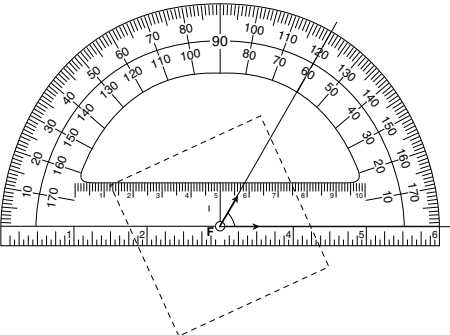

Copyright © Kendall Hunt Publishing Company

A. Record your angle description from the back of the $\angle F$ card.

B. What is the measure of $\angle F$? _____

C. Compare your estimate to your measurement.

Measuring and Estimating Angles SAB • Grade 4 • Unit 9 • Lesson 4 323

Student Activity Book - Page 323

Name _____ Date _____

2. Use Maya's method and your protractor to measure the size of a different angle from the Angle Sort Cards.

Copyright © Kendall Hunt Publishing Company

A. Record your angle size description from the back of the card.

B. What is the measure of your angle? _____ .

C. Compare your description to your measurement.

The Drawing Angles section of the *Student Guide* shows how to use a ruler and protractor to draw angles.

324 SAB • Grade 4 • Unit 9 • Lesson 4 Measuring and Estimating Angles

Student Activity Book - Page 324

Copyright © Kendall Hunt Publishing Company

Student Activity Book

Draw and Solve Problems with Angles

Questions 1–16 (SAB pp. 325–328)

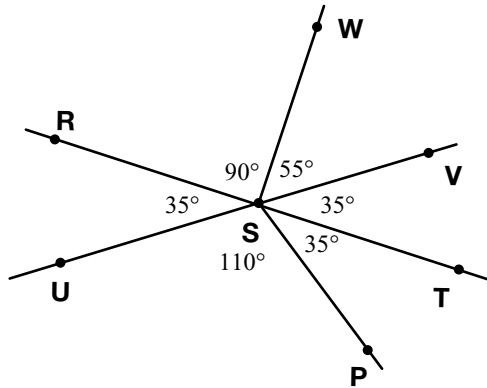

1. See figure above.
2. See figure above.
3. Possible response: $90^\circ - 35^\circ = 55^\circ$
4. See figure above.
5. $\angle RSU$. Possible response: $\overline{UV} = 180^\circ$, $\angle VSW = 55^\circ$, $\angle WSR = 90^\circ$, $55^\circ + 90^\circ = 145^\circ$, $180^\circ - 145^\circ = 35^\circ$
6. Possible response: $180^\circ - 35^\circ = 145^\circ$
7. A. $35^\circ + 35^\circ = 70^\circ$
 B. $35^\circ + 55^\circ = 90^\circ$
 C. $145^\circ + 35^\circ = 180^\circ$
 D. $55^\circ + 35^\circ + 35^\circ = 125^\circ$
 E. $35^\circ + 110^\circ + 35^\circ = 180^\circ$

8.

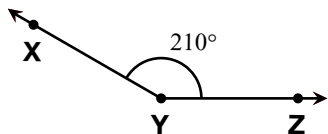
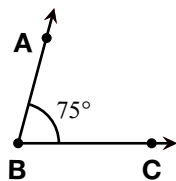

Copyright © Kendall Hunt Publishing Company

Name _____ Date _____

Draw and Solve Problems with Angles

Use the following figure to draw the angles below. Read all directions carefully.

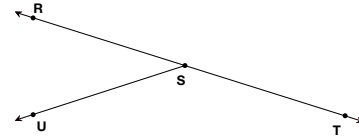

1. Draw and label $\angle TSV$ so it measures 35° .
2. Draw and label $\angle TSW$ so it measures 90° .
3. Write a number sentence to show the measurement of $\angle VSW$. Measure to check your solution.
4. Draw a different 35° angle and label it $\angle TSP$.
5. What other angle is equal to $\angle TSV$? _____ How do you know?
6. Write a number sentence to show the measurement of $\angle RSP$, then measure to check your solution.

Copyright © Kendall Hunt Publishing Company

Measuring and Estimating Angles

SAB • Grade 4 • Unit 9 • Lesson 4 325

Student Activity Book - Page 325

Name _____ Date _____

7. What are the measurements of the following angles? Write number sentences to show your solutions.
 - A. $\angle PST + \angle TSV =$ _____
 - B. $\angle PST + \angle VSW =$ _____
 - C. $\angle PSR + \angle VST =$ _____
 - D. $\angle WSV + \angle VST + \angle TSP =$ _____
 - E. Use the figure before Question 1 to find the sum of $\angle RSU + \angle USP + \angle PST$. Write a number sentence.

✓ Check-In: Questions 8-16

8. Draw $\angle ABC$ as 75° and $\angle XYZ$ as 210° .

Copyright © Kendall Hunt Publishing Company

326 SAB • Grade 4 • Unit 9 • Lesson 4

Measuring and Estimating Angles

Student Activity Book - Page 326

Answer Key • Lesson 4: Measuring and Estimating Angles

Name _____ Date _____

Describe the size of each angle in Questions 9–16. Then measure each of the angles with your protractor. You may need to extend the sides of some of the angles to measure.

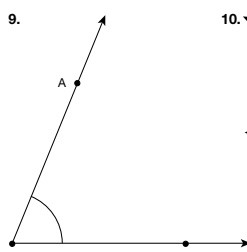
9. 

$\angle ABC$ is a little smaller than 90°
 $\angle ABC =$ _____

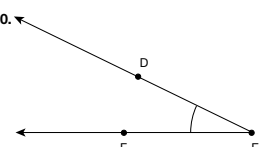
10. 

$\angle DEF$ is _____
 $\angle DEF =$ _____

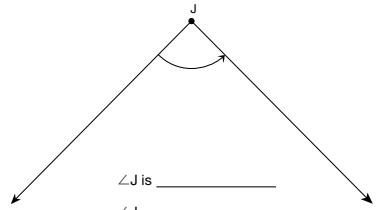
11. 

$\angle J$ is _____
 $\angle J =$ _____

Copyright © Kendall Hunt Publishing Company

Measuring and Estimating Angles SAB • Grade 4 • Unit 9 • Lesson 4 327

9–16: Responses will vary for each estimate. Sample responses are shown.

- 9. $\angle ABC = 68^\circ$
- 10. $\angle DEF$ is smaller than 90° , and closer to 0° .
 $\angle DEF = 26^\circ$.
- 11. $\angle J$ is close to 90° . $\angle J = 90^\circ$.
- 12. $\angle KLM$ is a reflex angle between 180° and 270° . $\angle KLM = 244^\circ$.
- 13. $\angle M$ is close to 90° . $\angle M = 90^\circ$.
- 14. $\angle P$ is close to 90° . $\angle P = 90^\circ$.
- 15. $\angle VWX$ is larger than 90° . $\angle VWX = 133^\circ$.
- 16. $\angle T$ is a reflex angle a little smaller than 270° .
 $\angle T = 255^\circ$.

Student Activity Book - Page 327

Name _____ Date _____

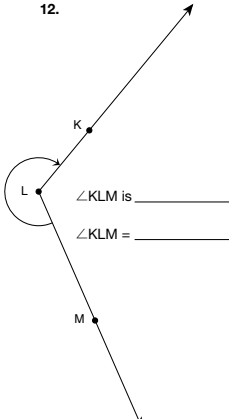
12. 

$\angle KLM$ is _____
 $\angle KLM =$ _____

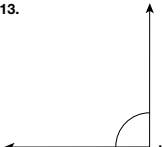
13. 

$\angle N$ is _____
 $\angle N =$ _____

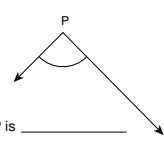
14. 

$\angle P$ is _____
 $\angle P =$ _____

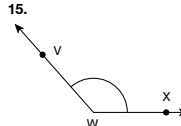
15. 

$\angle VWX$ is _____
 $\angle VWX =$ _____

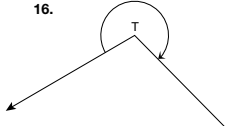
16. 

$\angle T$ is _____
 $\angle T =$ _____

Copyright © Kendall Hunt Publishing Company

328 SAB • Grade 4 • Unit 9 • Lesson 4 Measuring and Estimating Angles

Student Activity Book - Page 328

Copyright © Kendall Hunt Publishing Company